



## **Manual for GX-580**

### **Grinding Machine**

----- Version 1.1

## Table of Contents

<b>1. Instruction</b> .....	<b>1</b>
1.1 Summary .....	1
1.2 Liability .....	1
1.3 Warranty .....	1
<b>2. Safety</b> .....	<b>1</b>
2.1 Operation safety .....	1
2.2 Electrical safety .....	2
<b>3. General information</b> .....	<b>3</b>
3.1 Unpacking .....	3
3.2 Transport.....	3
3.3 Lifting.....	3
3.4 Machine name plate .....	3
3.5 Storage .....	3
<b>4. Machine description</b> .....	<b>4</b>
4.1 Standard delivery .....	4
4.2 General diagram.....	4
4.3 Main handle .....	5
4.4 Vacuum hose connection.....	6
4.5 Display panel .....	6
4.6 Handlebar adjustment .....	7
4.7 Handle adjustment.....	7
<b>5. Machine operation</b> .....	<b>8</b>
5.1 Machine working positions .....	8
5.2 Lifting the machine .....	10
5.3 Grinder operation .....	10
5.4 Changing abrasives.....	11
5.5 Grinding basics .....	12

<b>6. Machine maintenance</b> .....	<b>13</b>
6.1 Daily maintenance .....	12
6.2 Gear box service.....	12
6.3 Overload protection.....	13
<b>7. Troubleshooting</b> .....	<b>14</b>
<b>8. Technical data</b> .....	<b>15</b>
8.1 Dimensions.....	16

## **1. Introduction**

### **1.1 Summary**

XINGYI Machines are used for processing concrete floor surfaces. The scope of use of the machine can vary from rough to fine grinding and controlled by the tools used under the heads. This manual describes information on the use, repair, and maintenance of the grinder. Contact your local dealer for further information.

### **1.2 Liability**

We make every effort to make this manual as complete and accurate as possible, and we are not responsible for any errors or loss of information. XINGYI reserves the right to change the content in this manual without prior notice.

This manual is protected by copyright law and cannot be reproduced or used in any part without the express written consent of XINGYI.

### **1.3 Warranty**

This warranty only covers manufacturing defects. XINGYI bears no responsibility for damage that arises or occurs during transportation, unpacking or use. In no instance and under no circumstances shall the manufacturer be held responsible for damage and defects caused by incorrect use, corrosion or use outside the prescribed specifications. The manufacturer is not responsible for indirect damage or costs under any circumstances. For complete information on the manufacturer's warranty period, see XINGYI MACHINE USA's current warranty terms. Local distributors may have special warranty terms specified in their terms of sale, delivery and warranty. If there is any uncertainty regarding warranty terms, please contact your dealer.

## **2. Safety**

This manual indicates the important information / rules that must be observed when using this machine.

### **2.1 Operation Safety**

Users of machines from XINGYI have the ultimate responsibility for ensuring that everybody who works with or in the vicinity of the equipment follows all applicable safety rules. Safety measures must meet the requirements that apply to this type of equipment. Apart from the standard rules that apply in the workplace, the recommendations in this manual shall also be observed.

All work must be performed by trained personnel. Users of machines from XINGYI must have read through the dedicated manual for the machine. Incorrect use of the equipment could result in situations that could cause harm to the operator, the surroundings, or the machine.

Anyone using the machine shall know about:

- its functions
- location of emergency stops
- the safety rules for the work

The operator shall ensure that:

- No unauthorized person is stationed within the work area when the machine is started up

The workplace shall:

- be suitable for the purpose.
- be secured from loose objects that can be thrown out by the machine.
- be free from protruding bolts etc. on the surface to be processed.

Individuals in the workplace shall always use the recommended personal protective equipment and wear suitable clothing:

- safety glasses
- protective gloves
- steel toe safety shoes
- hearing protection
- respiratory mask
- Do not wear loose-fitting clothing or anything that can catch, such as scarves, bracelets, rings, etc.

General precautions:

- Check the machine is connected to a grounded power supply of the correct voltage.
- Work on live parts shall only be performed by qualified personnel.
- Suitable fire extinguishers should be clearly marked and close to hand.
- Maintenance of the equipment must not be performed during operation.

## **2.2 Electrical Safety**

- Work on electrical parts shall only be performed by qualified personnel.
- The cables and connectors shall meet the machine's specifications.
- The machine is equipped with an overload protector. Once the overload protector has tripped, power off and then power on to restart it.
- Check the cords before powering on. Any broken cords may cause a serious accident.
- The wires should be away from high temperature surfaces.
- Keep motor, electrical box, and inverter away from water.

### 3. General Information

#### 3.1 Unpacking

Check the packaging and equipment carefully on delivery for any possible transport damage. If there is any sign of damage, contact the dealer and report the damage by photos, report form or any other necessary evidence to the carrier immediately. Report packaging damage to the carrier as well. Check that the delivery meets the order. If you have any questions, please contact the dealer.

#### 3.2 Transport

Always make sure that the machine is securely anchored to its surroundings, and that the grinding head is on to the surface. Tighten the securing straps, or other equipment used for anchoring during transport over non-moving parts, e.g., the machine's chassis.

#### 3.3 Lifting

The machine can also be lifted using the lifting eyes provided or using other approved lifting equipment. In which case, make sure that the weights are locked in the forward position and that the handle is in its back position. When lifting the machine, lifting straps must be used.

#### 3.4 Machine Name Plate

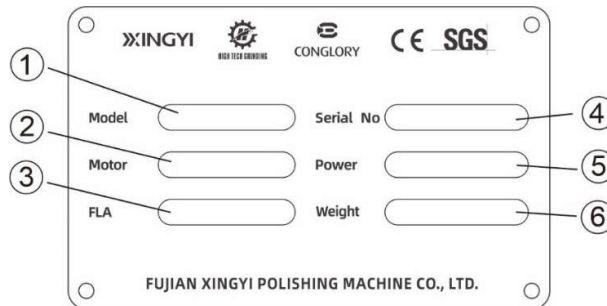

1. Model name	2. Rated power
3. Full load amps	4. Serial number
5. Rated voltage, phase, frequency	6. Weight

#### 3.5 Storage

The grinding machine should be stored in a heated, dry place at normal temperature when not in use. It may be damaged by condensation and cold.

## 4. Machine Description

The GX-580 Grinder is primarily used for rough grinding of concrete surfaces. The GX-580 is a 2 head counter rotary grinder, so it is good for coating removal and surface preparation. Different types of tooling can be used including metal bonded diamonds, ceramic bonded diamonds, and PCD tooling as well for coating removal. Because it is a single-phase machine it is easy to mobilize and set up on a job site, commercial or residential. The gear driven design give this machine the weight and torque that it needs to perform at a high production level. The GX-580 is equipped with a dust shroud and should always be connected to a dust extractor for safety and dust free operation. Xingyi Machine recommends the IVC-V3, or IVC-V2 single phase dust collector to pair with this model.

### 4.1 Standard Delivery

The machine will go with the following items. If anything is missing, please contact your dealer.

- full dust skirt, 1
- female power connector, 1 (male connector on the machine)
- keys for the main electrical box, 2
- 3” Velcro tooling adaptors (6)

### 4.2 General Diagram

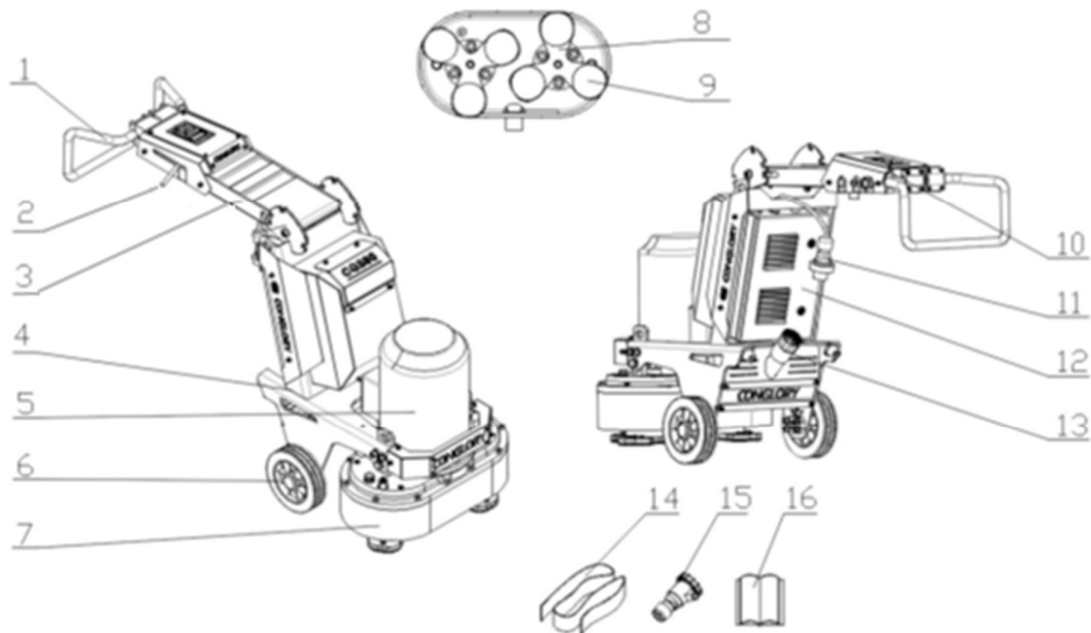

- |                                 |                              |
|---------------------------------|------------------------------|
| 1. Handlebar                    | 9. Tooling adapter           |
| 2. Main handle adjustment lever | 10. Handlebar adjustment pin |
| 3. Main handle                  | 11. Power connector (male)   |
| 4. Frame                        | 12. Electrical box           |
| 5. Motor                        | 13. Dust hose connection     |
| 6. Wheel                        | 14. Dust shroud              |
| 7. Gear box                     | 15. Power connector (female) |
| 8. Grinding head                | 16. Manual                   |

#### 4.3 Main Handle

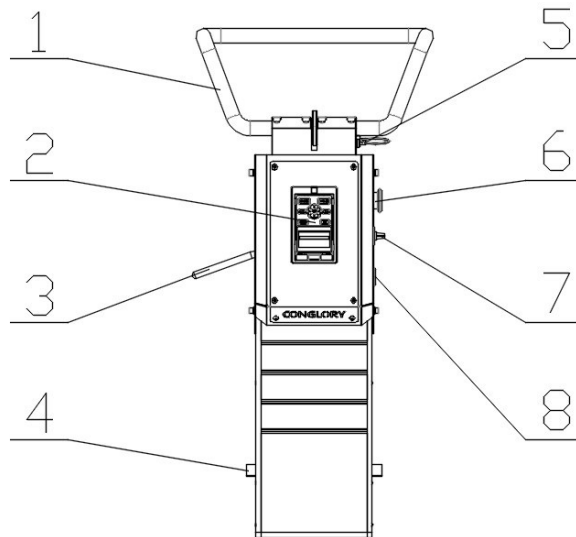

- |                                 |                                  |
|---------------------------------|----------------------------------|
| 1. handlebar                    | 5. handlebar adjusting pin       |
| 2. display                      | 6. emergency stop switch         |
| 3. main handle adjustment lever | 7. potentiometer for motor speed |
| 4. main handle locking pin      | 8. start button                  |

#### 4.4 Vacuum Hose connection

This machine is equipped with a vacuum hose connection system. It is a quick connect system making it easy to connect the hose to the dust collector. This machine is designed for dry grinding and should always be connected to a dust extraction system for safety of the operator and for those persons around the working area. When connected to the proper dust extractor this machine meets the requirements for the OSHA Table 1.

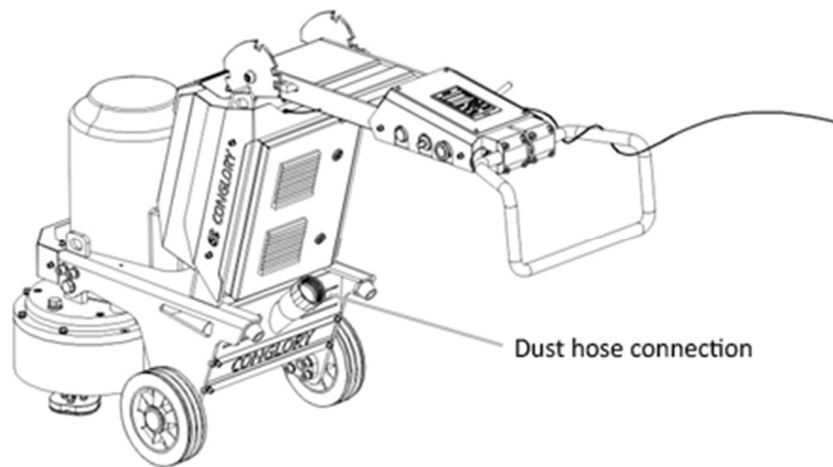

#### 4.5 Display Panel

The display screen provides the operator with information about the machine, including voltage, rpm, amps, error code if any, etc.

#### 4.6 Handlebar Adjustment

The handlebar adjusting pin can be moved to different positions to accommodate the specific user. Hold the handlebar with one hand, pull out the adjusting pin with the other hand, then release the adjusting bolt when it is rotated to proper position. Be sure that the pin has locked into a secure position.

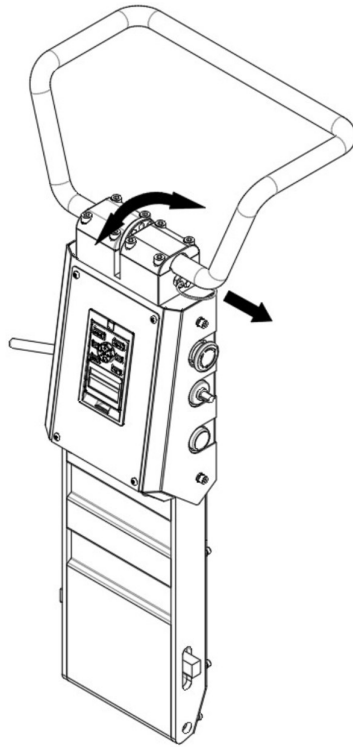

#### 4.7 Handle Adjustment

Use the handle position lever to adjust the position of the handle. Hold the handle tightly with one hand to support the handle, pull the lever lock back to release the handle, rotate the handle to a position that suits you best and release the lever to lock. Be sure that the handle has locked into a notch.

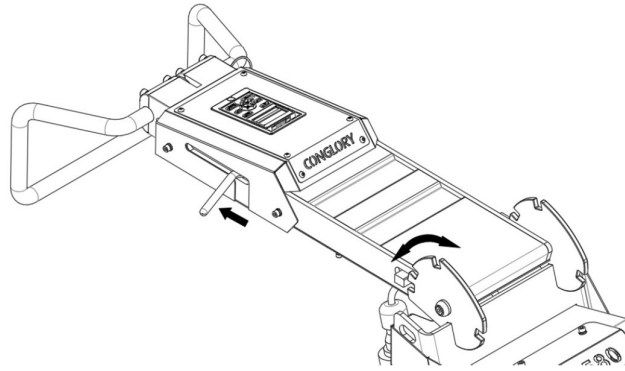

## 5.0 Machine Operation

The following section describes basic operation functions and operating positions for the machine. Grinders should be operated by trained personnel that understand the operation and safety features of the machine. Operator should always wear personal safety equipment, including safety glasses, hearing protection and proper clothing.

### 5.1 Machine Working Positions

During operation the handle on the grinder should be positioned to the best angle for the operator to control the grinder. Typically, 3 positions are used, 1 For tipping back the machine to change tooling. 2 For basic operation of the machine, and 3 For transport or storage of the machine.

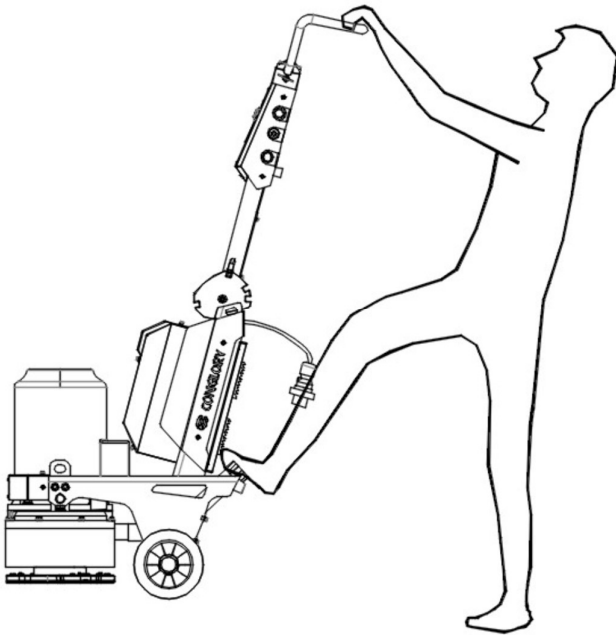

Tipping the grinder back

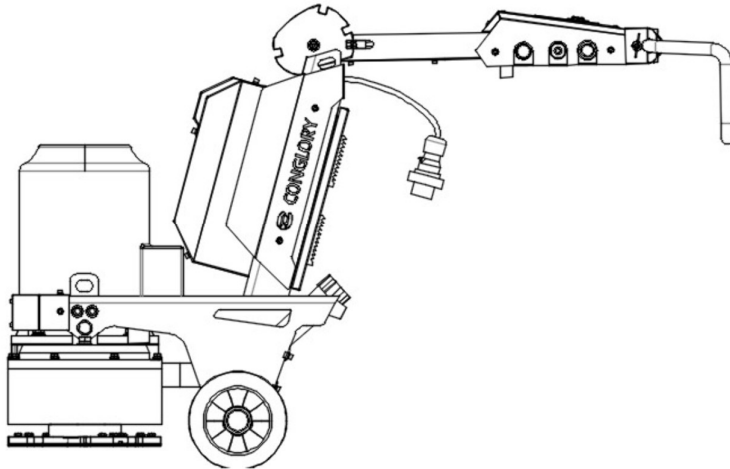

Operating position

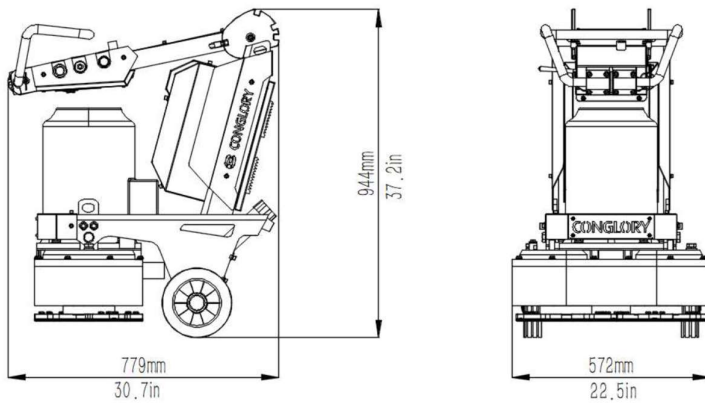

Transport or storage position

## 5.2 Lifting the Machine

When lifting the machine use the pick points located on the machine. Using proper lifting straps secured to both front and rear pick points, the machine will lift easily. The machine can also be placed on a pallet if using a forklift for lifting. Be sure that the machine is secured to the pallet with straps as well before lifting.

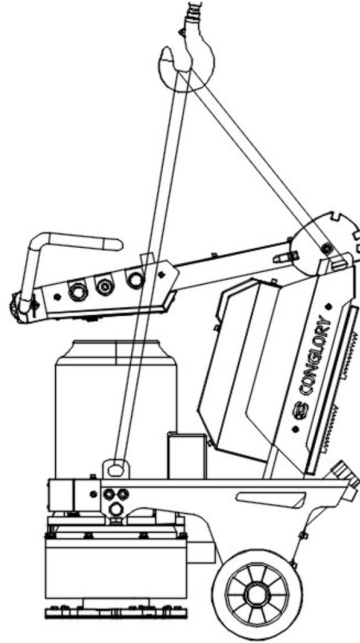

## 5.3 Grinder Operation

Place the machine where you intend to start grinding operations. Install the tooling on the grinding heads as needed for the operation. Connect the vacuum hose using the quick connector.

Make sure the emergency stop switch is pressed down (stop position). Plug in the power supply to the machine. Be sure it is the correct voltage for your machine, (240V single phase). Turn the emergency switch to the up position. Push the start button to start the machine, turn the potentiometer for the motor speed and the machine will begin grinding. Adjust the motor speed as needed for the tooling, the RPM can be read on the display panel.

Push the machine manually to move over the surface. Average speed for grinding should not exceed 8-10 feet per minute. To stop the machine, press down the emergency stop switch.

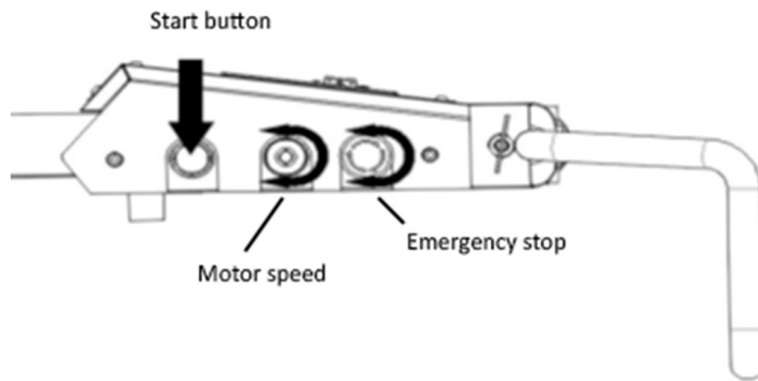

#### 5.4 Changing Abrasives

To change the abrasive tooling on the machine, tip the machine back and lay the handle flat on the floor. Wear glove to protect yourself from the heat. After grinding the gear box and the abrasive tooling will be at high temperatures. Using a screwdriver, remove the existing tooling from the machine. This is a good time to clean the heads using a brush or a vacuum. Replace the tooling on the heads with new abrasives. Return the machine to the upright position.

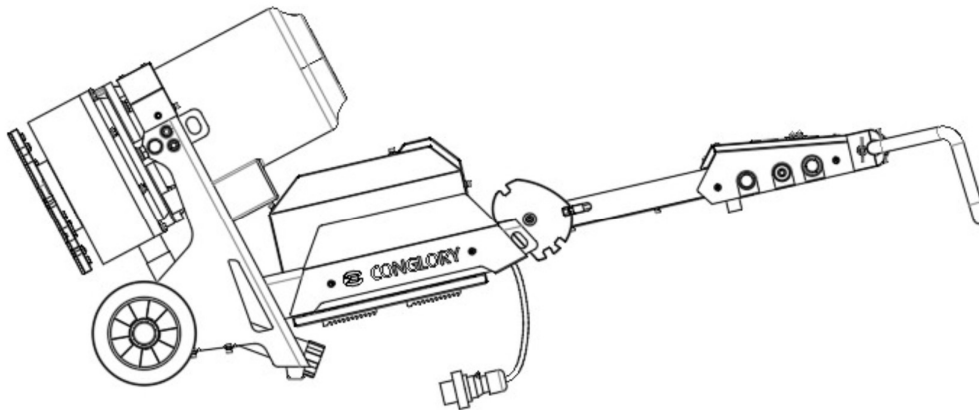

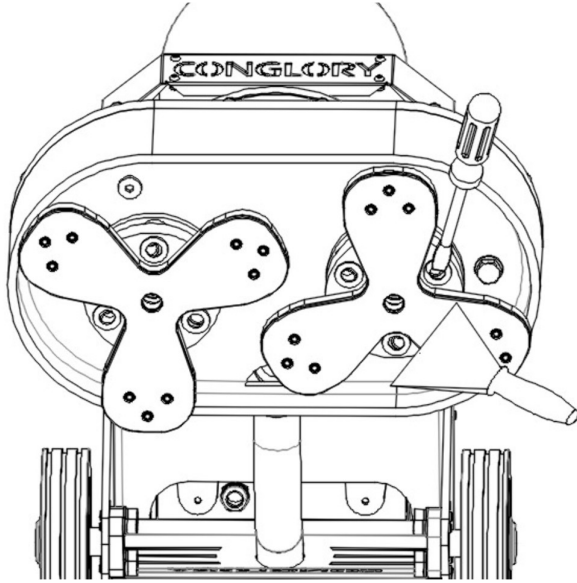

### 5.5 Grinding Basics

When grinding it is best to work close to the vacuum and work away from it. This will keep the dust hose behind the operator during operation.

The power cord should be run from the same position. This will always keep the power cord away from the grinding path.

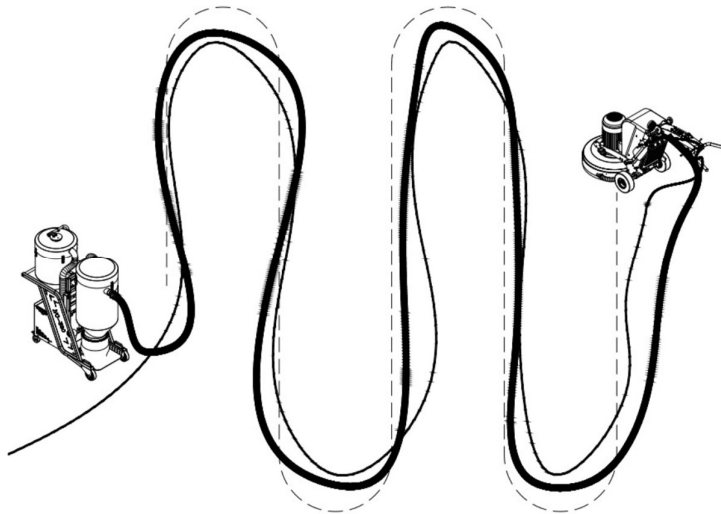

## **6. Machine Maintenance**

We recommend that the grinding machine be checked regularly to extend the service life. Always be sure that the machine is unplugged from power when performing maintenance or repairs.

### **6.1 Daily Maintenance**

Should include keeping the machine free of dust and as clean as possible. Use a vacuum to remove excess dust from the grinding heads and other critical areas of the machine. The grinding heads should be cleaned when changing abrasives, the magnets will collect dust and metal fragments from the tooling. This can cause the tools to not sit properly on the head; loose tools may fly off and or cause irregular scratches on the floor. Check the switches on the handle panel to ensure all the functions are working properly. Clean the switches as needed using a soft brush or cleaning rag. Do not use water to clean the switches.

### **6.2 Gear Box Service**

The machine gear box oil should be changed after the first 500 hours of operation, after that gear oil should be changed annually. There is a drain plug under the gear box, where the grinding plates are attached. The fill point is on top of the gear box cover. The CG-580 holds approx. 1 gallons/3.5L of gear oil. The recommended oil is VG320 or VG460, these are ISO-VG mm<sup>2</sup>/s DIN-51519, at 40°C.

Contact your retailer for service options and information or go to [www.xingyimachineusa.com](http://www.xingyimachineusa.com) for the video on changing gear oil.

### **6.3 Overload Protection**

The machine is equipped with an overload protection circuit for the inverter. When the machine becomes overloaded, the machine will shut down automatically to protect the inverter, the error will be displayed on the display panel. When this condition occurs disconnect the power from the machine and wait for the machine to cool down, typically 10-20 minutes, then reconnect the power and restart the machine.

## 7. Troubleshooting

Problem	Possible Cause	Solution
The Machine will not run	Emergency stop is engaged	Reset the stop switch
	The motor is jammed	Remove the debris
	Power cable damage	Replace the cable / check power supply
	Non-standard operation	Refer to operation manual
Machine is difficult to control / AMP draw is too high	Not enough tooling under the machine	Use the correct number of tools for the heads
	Power service not sufficient	Check the service amps
Machine stops immediately after starting		
	Overload protection	Reduce the load and restart
Machine bouncing	Tools are not set properly	Clean the heads and reset the tools
	Tools are different heights	Make sure the diamonds are all the same height, replace as needed

## 8. Technical Data

GX-580		
Motor power	5.5KW / 7.5HP	
Rated voltage	1P 240V	1P 220V
Rated AMPS	25 A	25A
Input hertz	50HZ / 60HZ	
Inverter power	5.5KW / 7.5HP	
Working width	580mm / 22.8 in	
Grinding disc size	310mm / 12in	
Motor speed	450-1680 RPM	
Head weight	103.5KG/650lbs	
Dimensions / packed	779 x 572 x 944mm/30.7 x 22.5 x 37.2in	
Dimensions /operation	1487 x 572 x 944mm/58.5 x 22.5 x 37.2in	
Total weight	228 KG/502 LBS	
Cable size	6mm /8/3	
Storage temperature	-20° - 60°C /-4°-140°F	
Operating temperature	-10°-40°C /14°-104°F	
Humidity	Below 95% (no condensation)	

### 8.1. Dimensions

