



Manual for 250-D Grinding Machine

----- Version 1.1

Table of Contents

1. Instruction	1
1.1 Summary	1
1.2 Liability	1
1.3 Warranty	1
2. Safety	1
2.1 Operation safety	1
2.2 Electrical safety	2
3. General information	3
3.1 Unpacking	3
3.2 Transport.....	3
3.3 Lifting.....	3
3.4 Movement.....	3
3.5 Machine name plate	3
3.6 Storage	4
4. Machine description	4
4.1 Standard delivery	4
4.2 General description.....	5
4.3 Handle adjustments	6
4.4 Wheel level adjustment	7
4.5 Grinding angel adjustment.....	7
5. Operation	10
5.1 General	10
5.2 Handle adjustment.....	10
5.3 Access to grinding tools	11
5.4 Fitting grinding tools	13
5.5 Fitting cup wheel.....	13
5.6 Maneuvering	14
5.7 Making operation easier	14
5.8 Transportation	15

6. Maintenance and Repair	15
6.1 Prior to each new grinding process.....	15
6.2 Daily.....	15
6.3 Weekly.....	15
6.4 Repairs.....	16
6.5 Spare parts	16
7. Troubleshooting	17
7.1 the machine will not start	17
7.2 Fuse or earth fault breaker trip frequently.....	17
7.3 the machine cannot cope	18
8. Technical data	19

1. Introduction

1.1 Summary

XINGYI Machine are used for processing the floor surface. The scope of use of the machine depends on the choice of tools. In addition to the use and general functions, this manual describes information on the use, repair, and maintenance of the grinder. Contact your local dealer for further information.

1.2 Liability

We make every effort to make this manual as complete and accurate as possible, and we are not responsible for any errors or loss of information. XINGYI reserves the right to change the instructions in this manual without prior notice.

This manual is protected by copyright law and cannot be reproduced or used in any part without the express written consent of XINGYI.

1.3 Warranty

This warranty only covers manufacturing defects. XINGYI bears no responsibility for damage that arises or occurs during transportation, unpacking or use. In no instance and under no circumstances shall the manufacturer be held responsible for damage and defects caused by incorrect use, corrosion or use outside the prescribed specifications. The manufacturer is not responsible for indirect damage or costs under any circumstances. For complete information on the manufacturer's warranty period, see XINGYI MACHINE USA's current warranty terms. Local distributors may have special warranty terms specified in their terms of sale, delivery, and warranty. If there is any uncertainty regarding warranty terms, please contact your dealer.

2. Safety

This manual indicates the important information / rules that must be observed when using XINGYI's machine.

2.1 Operation safety

Users of machines from XINGYI have the ultimate responsibility for ensuring that everybody who works with or in the vicinity of the equipment follows all applicable safety rules. Safety measures must meet the requirements that apply to this type of equipment. Apart from the standard rules that apply in the workplace, the recommendations in this manual shall also be observed.

All work must be performed by trained personnel. Users of machines from XINGYI must have read through the dedicated manual for the machine. Incorrect use of the equipment could result

in situations that could cause harm to the operator, the surroundings, or the machine.

Machines from XINGYI may only be used in the way recommended by XINGYI. Machines from XINGYI may only be used for commercial purposes.

Anyone using the machine shall know about:

- its functions
- location of emergency stops
- the safety rules for the work

The operator shall ensure that:

- No unauthorized person is stationed within the work area when the machine is started up

The workplace shall:

- be suitable for the purpose.
- be secured from loose objects that can be thrown out by the machine.
- be free from protruding bolts etc. on the surface to be processed.

Individuals in the workplace shall always use the recommended personal protective equipment and wear suitable clothing:

- safety goggles
- protective gloves
- steel toe safety shoes
- hearing protection
- respiratory mask
- Do not wear loose-fitting clothing or anything that can catch, such as scarves, bracelets, rings, etc.

General precautions:

- Check the machine is connected to an earthed wall socket.
- Work on live parts shall only be performed by qualified personnel.
- Suitable fire extinguishers should be clearly marked and close to hand.
- Maintenance of the equipment must not be performed during operation.

2.2 Electrical safety

- Work on live parts shall only be performed by qualified personnel.
- The cables and connectors shall meet the machine's specifications.
- The machine is equipped with an overload protector. Once trip the overload protector, power off and then power in to resume it.

- Check the cords before powering in. Any broken cords may cause a serious accident.
- The wires should be away from the high temperature surface.
- Keep motor, electrical box, inverter away from water.

3. General information

3.1 Unpacking

Check the packaging and equipment carefully on delivery for any possible transport damage. If there is any sign of damage, contact the dealer and report the damage by photos, report form or any other necessary evidence in the first place. Report packaging damage to the carrier as well.

Check whether the delivery meets the order. If you have any questions, please contact the dealer.

3.2 Transport

Always make sure that the machine is securely anchored to its surroundings and that the grinding head is lowered on to the surface. Tighten the securing straps, or other equipment used for anchoring during transport over non-moving parts, e.g. the machine's chassis.

3.3 Lifting

The machine can also be lifted using the lifting eyes provided or using other approved lifting equipment. In which case, make sure that the weights are locked in the forward position and that the handle is in its back position. When lifting the machine, lifting straps must be used.

3.4 Movement

When moving on sloping surfaces, e.g. loading ramps, the machine should be secured in the lifting eyes, for example, using a winch. This is a safety measure in case the machine starts to roll out of control or tip over. The weights should be in the forward position. Otherwise, there is a risk that the machine tips backwards. Ensure there is no one below the machine during movement on sloping surfaces.

3.5 Machine name plate

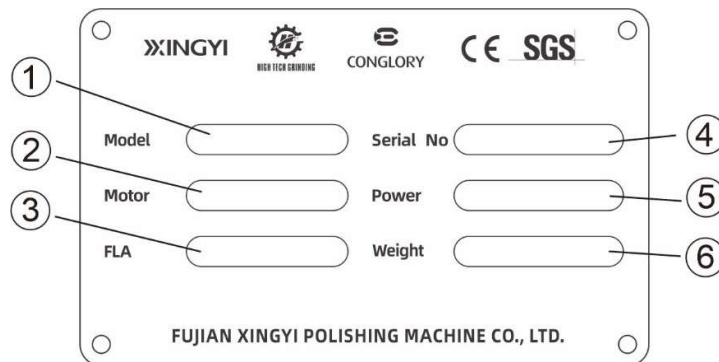

1. Model name	2. Rated power
3. Full load amps	4. Serial number
5. Rated voltage, phase, frequency	6. Weight

3.6 Storage

The grinding machine should be stored in a heated, dry place at normal temperature when not in use. It may be damaged by condensation and cold.

4. Machine description

250-D is a speed dis-adjustable, single head, and single-phase edge grinder. It is an ideal machine for small rooms and edges. It can run 10” cup wheel, or standard polishing tools including double segment tools, PCD’s, resin and ceramic bonded tools.

The handle can be set in different tilt positions. Choose a position that suits you best.

The edge dust cover is used when it deals with the edge and the round dust cover is used in normal area. The cover together with the connected vacuum system provide the conditions needed for a good work environment. The cover ensures that the operator does not encounter rotating mechanical parts and exposure to dust is minimized. Because the cover is floating, the dust uptake is optimized since it is always in contact with the surface.

Always make sure that a dust extractor is connected to the grinder during dry grinding to prevent as far as possible exposure to dust particles of operators, people in the vicinity, and meets OSHA rules.

4.1 Standard delivery

The machine will go with the following items. If anything is lost, please contact your dealer.

- Operation manual, 1
- Velcro adapters, 3
- Round dust cover, 1
- Edge dust cover, 1
- Wrench, 1

4.2 General description



- 1, handlebar
- 2, emergency stop
- 3, starter
- 4, breaker
- 5, handle
- 6, electrical connection
- 7, locking pin

- 8. handle position wheel
- 9, water tank
- 10, water valve
- 11, motor
- 12, grinding head
- 13, travel wheel

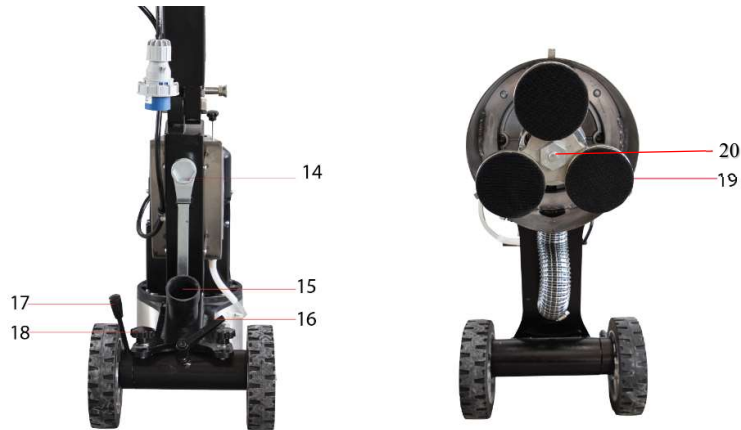

- 14, wrench
- 15, connection, dust extractor
- 16, handle for the wheel level locking
- 17, lever for wheel level adjustment
- 18, knob for grinding angle adjustment
- 19, grinding plate
- 20, hexagon nut

4.3 Handle adjustments.

The handle can be set in different tilt positions to get the best position for operation. When setting the handle, one hand holds the handle for supporting, the other hand pulls out the locking pin **7** from the handle position wheel **8** and rotate the handle to a position that suits you best and insert the pin **7** to the handle position wheel **8**(see below pic).

Heads up: check the handle position wheel first to understand the range of adjustment.

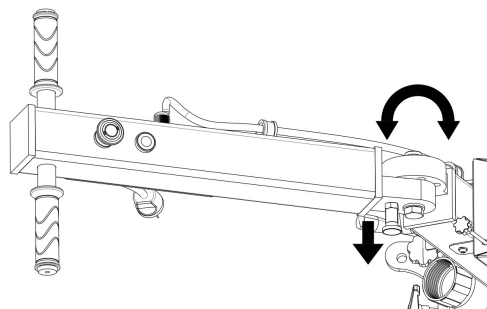

4.4 Wheel level adjustment

This is used to adjust the level of two wheels and the grinding head.

Pull up **16** and turn it in counterclockwise direction to unlock the wheel level. Push **17** forward or pull backward to adjust the wheel level in the proper position. And turn **16** in clockwise direction to lock the wheel level (see below pics).

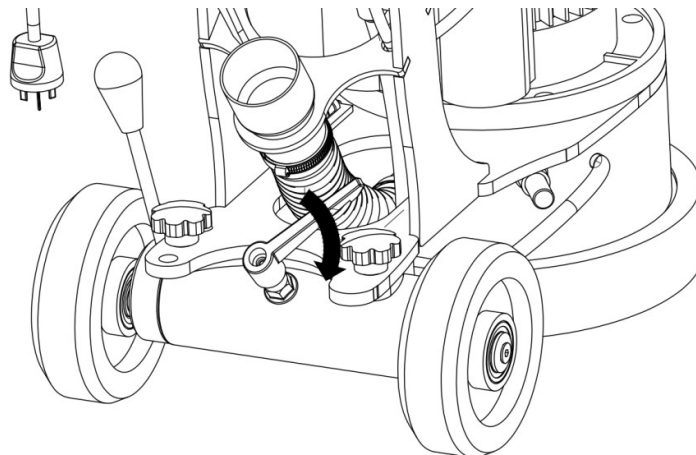
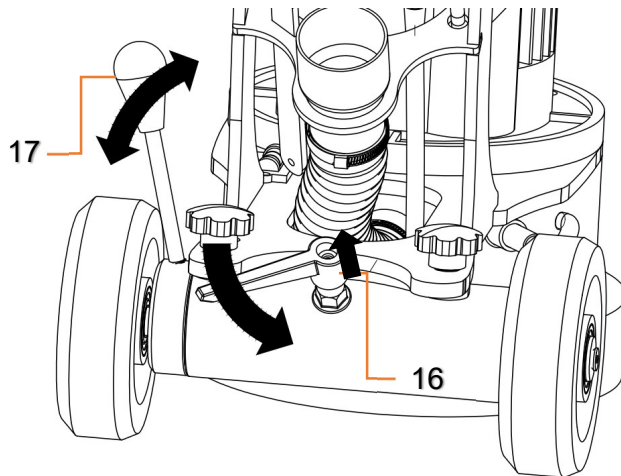

4.5 Grinding angle adjustment

When the machine is working in a narrow space, or to deal with corners or edges, it would be helpful to achieve the purpose by adjusting the angle between the grinding head and the wheel shaft. 3 positions are available (see below pics):

- Position 1 (60 degree)
- Position 2 (90 degree)
- Position 3 (120 degree)

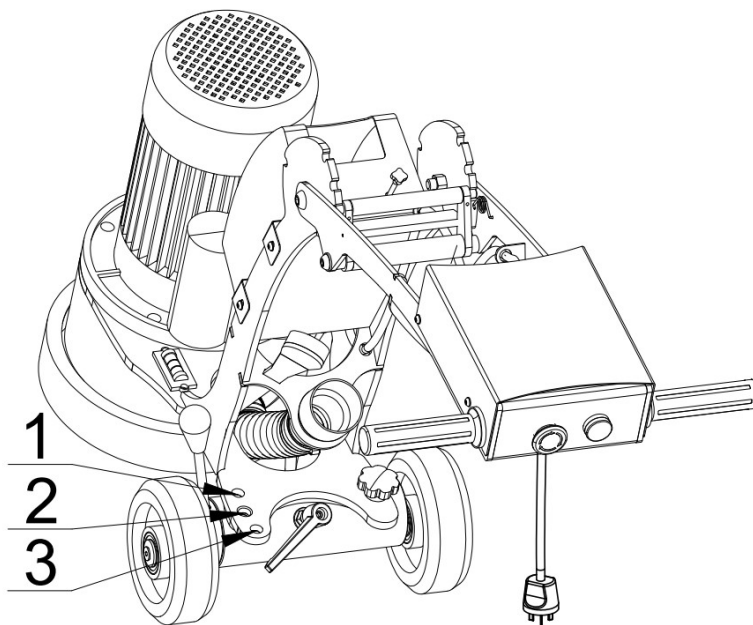

Position 1:

Unscrew the knob in counterclockwise direction. Swing the grinding head to the left until the upper hole is aligned up. Place the knob and tighten.

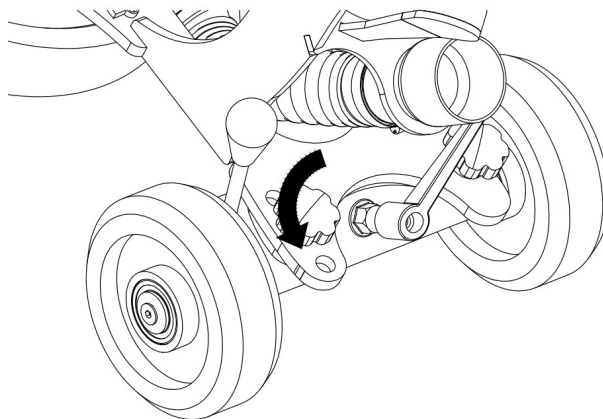

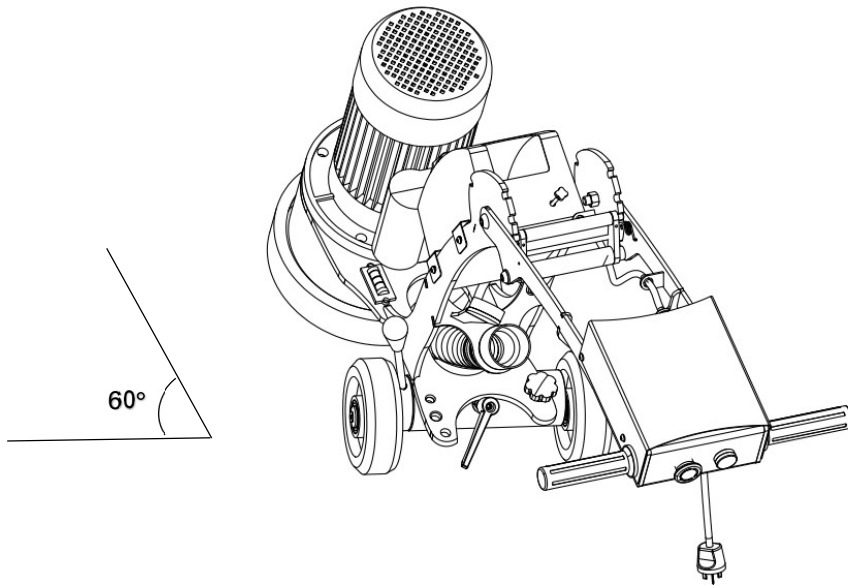

Position 2:

Unscrew the knob in counterclockwise direction. Swing the grinding head to the center until the middle hole is aligned up. Place the knob and tighten.

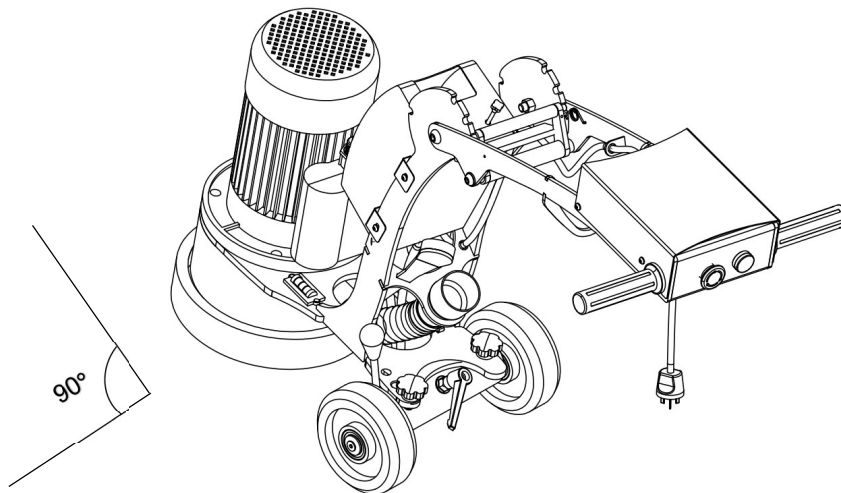

Position 3:

Unscrew the knob in counterclockwise direction. Swing the grinding head to the right until the lower hole is aligned up. Place the knob and tighten.

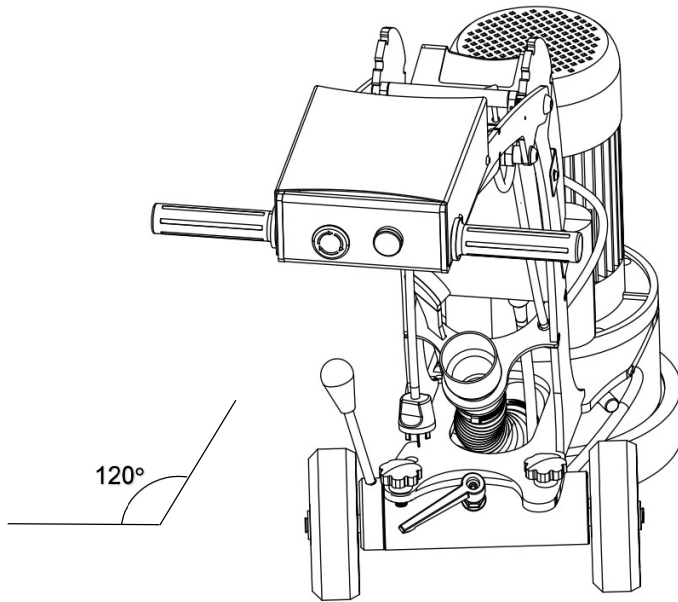

5. Operation

5.1 General

The following section describes how to change tools and how to operate the grinding machine.

5.2 Handle adjustments

Place in the right working height using the various settings. Ensure that the handle locking pin locks properly in the position wanted when adjusting the handle.

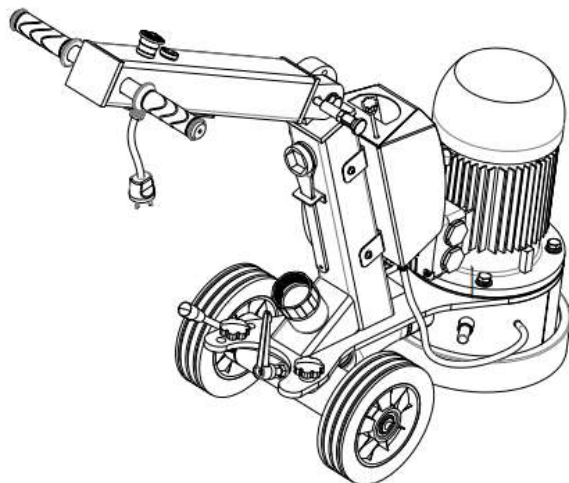

5.3 Access to grinding tools.

WARNING



Risk of crushing.

Risk for personal injury and mechanical damage.

Disconnect the power prior to cleaning, maintenance, change of tools and repair.

Raise the handle to the highest position in accordance with the Handle Settings page. Two hands hold the handle grips and place a foot on the foot pedal (between two wheels). The machine may be heavy. Carefully, tip the machine backwards until all of the machine reaches the floor.

Ensure that the machine lies supported on the handle.

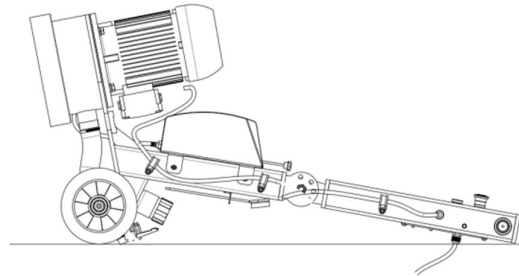
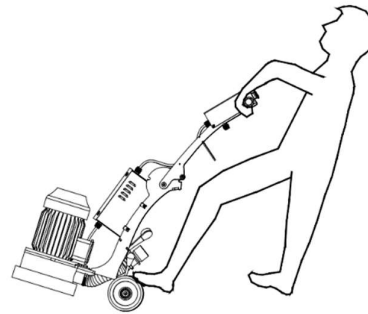
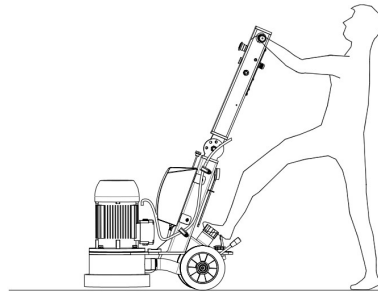

5.4 Fitting grinding tools

The machine uses 3 grinding tools.

Press tool plate locking pin **21** to lock the plate. Insert the flat screwdriver into the slot to remove the Velcro adapter. Align the 3 holes on the tool with the 3 pins on the plate and the tool will be attached immediately by magnet which is embedded in the tool plate. Unlock the tool plate.

The tool plate holds the tools in place for the grinding application.

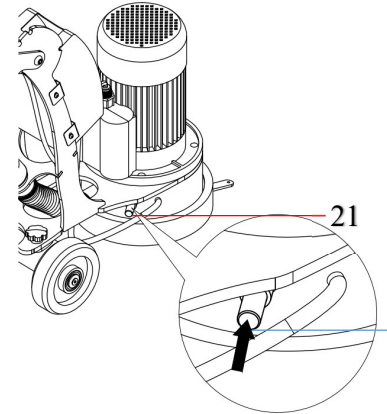

5.5 Fitting cup wheel

The machine uses a 10" cup wheel as well.

Press tool plate locking pin **21** to lock the plate. Unscrew hexagon nut **20** with the wrench attached to the back of machine and remove the tool plate. Place the 10" cup wheel and tighten it. Unlock the tool plate.

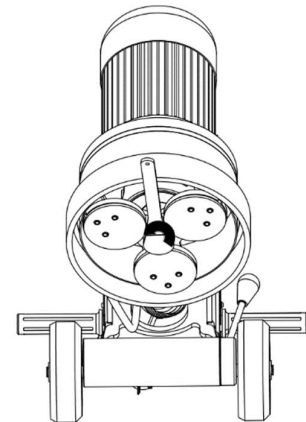
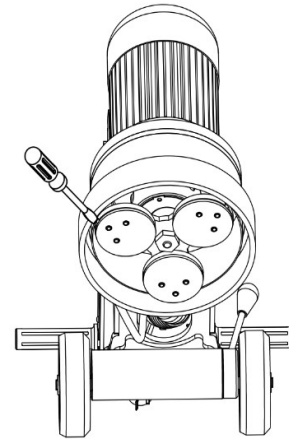

5.6 Maneuvering

Connect a dust extractor to the machine. For available models of dust extractors, go to XINGYI's website www.xingyimachineusa.com for more information.

Place the handle in the working position.

Start the dust extractor if dry grinding is to be done.

Make sure the emergency stop **2** is not activated. If not, turn clockwise according to arrows on the switch.

Press the starter **3**. When the machine is not in use, press the emergency stop **2** to switch the machine off.

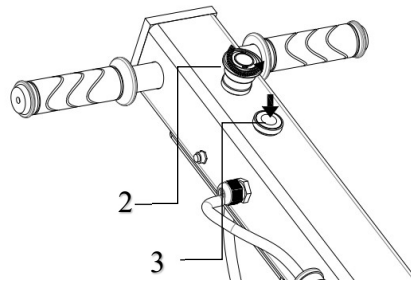

5.7 Making operation easier.

To keep the suction hose for the dust extractor and the power cable out of the working area and/or path of the machine, the hose and cable can be arranged as shown in the picture below.

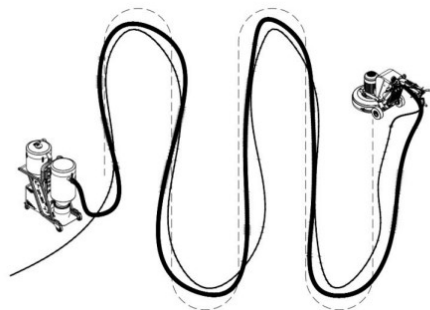

5.8 Transportation

When transporting, tilt the handle to the front for the smallest size and the safest position.

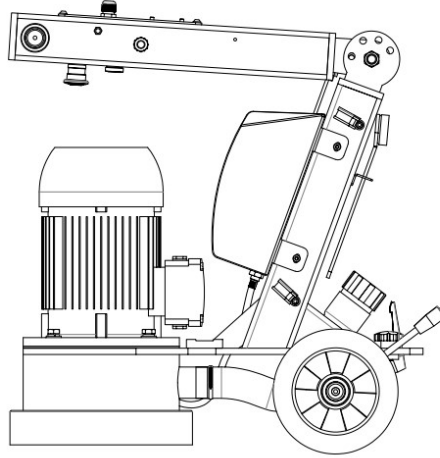

6. Maintenance and Repair

Always clean the machine after use. Only use high-pressure washer on grinding head and hose and sponge on the rest of the machine.

Vacuum clean the electrical cabinet, control panel.

6.1 Prior to each new grinding process

Check the tool plate and coupler to ensure that no damage or cracks have arisen. Replace parts if there is any damage.

6.2 Daily

- Check the emergency stop function.
- Check for wear to the grinding tools – abnormal or uneven wear may indicate a worn coupler.
- Check the tool plate and coupler to ensure that no damage or cracks have arisen. Replace parts if there is any damage.
- Check the connection of hose and cables. Adjust if necessary.

6.3 Weekly

- Clean machine.
- Check the handle's locking function. Replace the bushes, if necessary.
- Check warning decal.
- Check the grinding cover – seal, wear, cracks, brush list, extraction, hoses, coupler.
- Electrical cabinet – check seals.
- Electrical cables – check wear and attachment.

6.4 Repairs

All repairs that may need to be performed must be done by one of the XINGYI authorized service centers. Contact your dealer if your machine requires servicing. For contact information, check the company website www.xingyimachineusa.com.

6.5 Spare parts

To ensure rapid delivery of spare parts, always specify the model, the machine's serial number and the spare part number when ordering. Information on the model and serial number can be found on the machine's name plate. Information on spare part numbers can be found in the machine's spare parts list, which is available to read or print out from the enclosed digital media. If you have any questions, please contact your nearest XINGYI's dealer. Only original tools and spare parts from XINGYI may be used. Otherwise, the warranty will be invalid.

7. Troubleshooting

This chapter describes some of the possible failures and how to handle them. If you still cannot resolve it or have an error, please contact your nearest dealer.

7.1 The machine will not start.

Fault description	Cause	Correction
Electrical supply	Fault on supply, e.g. fuses, earth fault breakers or connecting cables	Check correct voltage on incoming phase/phases
Power supply	Power supply indication is not lit	Check miniature circuit Breaker 25

7.2 Fuse or earth fault breaker trip frequently

Fault description	Cause	Correction
Earth fault braker trips	cabling or inverter	Too high a leakage current/earth fault.
Fuse trips.	Too high a load or too small fuses	Check size of fuses and inertia.
		Reduce the machine's load by reducing the grinding pressure, lower the rpm or by changing tool. See the machine's power meter.

7.3 The machine cannot cope.

Fault description	Cause	Correction
The machine cannot cope	Too high a load	Reduce the grinding pressure.
		If the machine runs at high speed, lower the rpm so the machine becomes stronger. See meter for available power.
		Voltage drop, check the voltage meter during grinding.
		Too sticky a coating on the surface being processed.
		Run half of the machine on the surface to be cleaned and half on the clean surface. This removes any residue from the tools.
		Check the tools. Ensure that the correct tools are used, that they are in working order and that they are correctly fitted.

8. Technical data

The table and picture show the technical data and dimensions of the machine.

250-D	
Engine power	<i>2.2 KW / 3 HP</i>
Rated voltage	<i>Single Phase, 110 V</i>
Rated current	<i>25 amps</i>
Hertz	<i>50HZ / 60HZ</i>
Working width	<i>250 mm / 10 inch</i>
rpm	<i>1460</i>
Packing size (L-W-H)	<i>697×386×737 mm / 27×15×29 inch</i>
Dimension (max.L-max.W-max.H)	<i>812×386×1190 mm / 32×15×47 inch</i>
Total Weight	<i>60 kg / 133 lbs</i>
AWG	<i>10</i>
Storage temperature	<i>-20 ~ +60°C / -4 ~ +140°F</i>
Operating temperature	<i>-10 ~ +40°C / +14 ~ +104°F</i>
Humidity	<i>Below 95% (no condensation)</i>